



Operating Instructions and Parts Manual Lever Operated Chain Hoist JLH Series



1 Ton model shown

JET
427 New Sanford Road
LaVergne, Tennessee 37086
Ph.: 800-274-6848
www.jettools.com

Part No. M-275050
Revision H1 05/2016
Copyright © 2015 JET

Warranty and Service

JET warrants every product it sells against manufacturers' defects. If one of our tools needs service or repair, please contact Technical Service by calling 1-800-274-6846, 8AM to 5PM CST, Monday through Friday.

Warranty Period

The general warranty lasts for the time period specified in the literature included with your product or on the official JET branded website.

- JET products carry a limited warranty which varies in duration based upon the product. (See chart below)
- Accessories carry a limited warranty of one year from the date of receipt.
- Consumable items are defined as expendable parts or accessories expected to become inoperable within a reasonable amount of use and are covered by a 90 day limited warranty against manufacturer's defects.

Who is Covered

This warranty covers only the initial purchaser of the product from the date of delivery.

What is Covered

This warranty covers any defects in workmanship or materials subject to the limitations stated below. This warranty does not cover failures due directly or indirectly to misuse, abuse, negligence or accidents, normal wear-and-tear, improper repair, alterations or lack of maintenance. JET woodworking machinery is designed to be used with Wood. Use of these machines in the processing of metal, plastics, or other materials outside recommended guidelines may void the warranty. The exceptions are acrylics and other natural items that are made specifically for wood turning.

Warranty Limitations

Woodworking products with a Five Year Warranty that are used for commercial or industrial purposes default to a Two Year Warranty. Please contact Technical Service at 1-800-274-6846 for further clarification.

How to Get Technical Support

Please contact Technical Service by calling 1-800-274-6846. **Please note that you will be asked to provide proof of initial purchase when calling.** If a product requires further inspection, the Technical Service representative will explain and assist with any additional action needed. JET has Authorized Service Centers located throughout the United States. For the name of an Authorized Service Center in your area call 1-800-274-6846 or use the Service Center Locator on the JET website.

More Information

JET is constantly adding new products. For complete, up-to-date product information, check with your local distributor or visit the JET website.

How State Law Applies

This warranty gives you specific legal rights, subject to applicable state law.

Limitations on This Warranty

JET LIMITS ALL IMPLIED WARRANTIES TO THE PERIOD OF THE LIMITED WARRANTY FOR EACH PRODUCT. EXCEPT AS STATED HEREIN, ANY IMPLIED WARRANTIES OF MERCHANTABILITY AND FITNESS FOR A PARTICULAR PURPOSE ARE EXCLUDED. SOME STATES DO NOT ALLOW LIMITATIONS ON HOW LONG AN IMPLIED WARRANTY LASTS, SO THE ABOVE LIMITATION MAY NOT APPLY TO YOU.

JET SHALL IN NO EVENT BE LIABLE FOR DEATH, INJURIES TO PERSONS OR PROPERTY, OR FOR INCIDENTAL, CONTINGENT, SPECIAL, OR CONSEQUENTIAL DAMAGES ARISING FROM THE USE OF OUR PRODUCTS. SOME STATES DO NOT ALLOW THE EXCLUSION OR LIMITATION OF INCIDENTAL OR CONSEQUENTIAL DAMAGES, SO THE ABOVE LIMITATION OR EXCLUSION MAY NOT APPLY TO YOU.

JET sells through distributors only. The specifications listed in JET printed materials and on official JET website are given as general information and are not binding. JET reserves the right to effect at any time, without prior notice, those alterations to parts, fittings, and accessory equipment which they may deem necessary for any reason whatsoever. JET® branded products are not sold in Canada by JPW Industries, Inc.

Product Listing with Warranty Period

90 Days – Parts; Consumable items
1 Year – Motors; Machine Accessories
2 Year – Metalworking Machinery; Electric Hoists, Electric Hoist Accessories; Woodworking Machinery used for industrial or commercial purposes
5 Year – Woodworking Machinery
Limited Lifetime – JET Parallel clamps; VOLT Series Electric Hoists; Manual Hoists; Manual Hoist Accessories; Shop Tools; Warehouse & Dock products; Hand Tools; Air Tools

NOTE: JET is a division of JPW Industries, Inc. References in this document to JET also apply to JPW Industries, Inc., or any of its successors in interest to the JET brand.

Table of Contents

Warranty and Service.....	2
Table of Contents.....	3
Warning.....	4
Introduction.....	5
Specifications (JLH-75/100/150/250WO).....	6
Specifications (JLH-300/600/900).....	7
Unpacking.....	8
Contents of the Carton.....	8
Installation.....	8
Pre-Operation Inspection.....	8
Inspecting the Load Chain.....	8
Inspecting Hooks.....	9
Other Inspections.....	9
Operation.....	10
Precautions.....	11
Point Hooks.....	11
Overload Protection.....	11
Allowable Limits for Load Chain and Hooks.....	12
Load Chain.....	12
Hooks (Top and Bottom).....	12
Inspection and Maintenance.....	11
Timing Marks for Gear Replacement.....	13
Troubleshooting.....	13
Replacement Parts.....	14
JLH Series Lever Hoists (JLH-75/100/150/250/300/600/900WO).....	14
Parts List: JLH-75WO (0.75 Ton).....	15
Parts List: JLH-100WO (1 Ton).....	17
Parts List: JLH-150WO (1.5 Ton).....	19
Parts List: JLH-250WO (2.5 Ton).....	21
Parts List: JLH-300WO (3 Ton).....	23
Parts List: JLH-600WO (6 Ton).....	25
Parts List: JLH-900 (9 Ton).....	27



Warnings

1. Read and understand the entire owner's manual before attempting operation. Failure to comply with instructions and warnings may cause serious injury.
2. This lever hoist is designed and intended for use by properly trained and experienced personnel only. If you are not familiar with the proper and safe operation of a lever hoist, do not use until proper training and knowledge have been obtained.
3. Do not use this lever hoist for other than its intended use. If used for other purposes, JET disclaims any real or implied warranty and holds itself harmless from any injury that may result from that use.
4. Do not use lever hoist to lift, support or transport people; or to lift or support loads over people.
5. Do not exceed the rated capacity of the hoist.
6. Do not attempt to extend the lever handle using a "cheater pipe" or any other such device.
7. Do not strike the lever handle with a hammer or any other object.
8. Do not use the chain as a sling. This may cause damage to the chain.
9. Always inspect the lever hoist for damage prior to use. If hoist is damaged, do not use until it has been repaired or replaced.
10. Do not use more than one lever hoist to lift or move a load. If this is unavoidable, each hoist must have the same capacity as the load to be moved.
11. Never allow chain to "set" over sharp edges. All pulls or lifts must be made with straight chain that is free of obstacles.
12. If the lever handle is difficult to operate, then the load exceeds the capacity of the hoist. Reduce load or select a hoist of larger capacity.
13. Do not use hoist if the chain is twisted, kinked or damaged.
14. Do not operate hoist unless load is centered between top and bottom hooks.
15. On hoists with the overload warning lever, do not use this device to measure load weight.
16. Always take time to study the job to be performed and choose the safest method. Do not place yourself or other people in an unsafe position.
17. Always maintain your balance and firm footing when operating the lever hoist.
18. Leave all internal maintenance and inspections to a qualified Walter Meier Service Center.
19. Do not attempt to lengthen or repair load chain.
20. Replace chain with factory replacement chain only. Do not use any other type of chain.
21. If welding near the hoist, do not allow the chain or hook to be touched by a live electrode. Prevent weld splatter upon the chain.
22. Never use the hoist if either hook is stretched, deformed, or has a broken or missing safety latch. Always replace the safety latch and/or the hook before placing the hoist back in service.
23. Be sure supporting structures and load-attaching devices used in conjunction with this lever hoist provide an adequate safety factor to handle the rated load plus the weight of the equipment. If in doubt, consult a qualified structural engineer.
24. Understand and follow all procedures as set forth in American National Standards titled "Performance Standard for Manually Lever Operated Chain Hoists," ANSI/ASME HST-3; and "Manually Lever Operated Hoists," ANSI/ASME B30.21. These standards are available through the American Society of Mechanical Engineers at www.asme.org.
25. Keep visitors a safe distance from the work area. **Keep children away.**

Introduction

This manual is provided by JET covering the safe operation and maintenance procedures for the JET JLH-Series Lever Hoists. This manual contains instructions on installation, safety precautions, general operating procedures, maintenance instructions and parts breakdown. This tool has been designed and constructed to provide consistent, long-term operation if used in accordance with instructions set forth in this manual. If there are any questions or comments, please contact either your local supplier or JET. JET can also be reached at our web site: www.jettools.com.

The JET JLH-Series Lever Hoists comply with ANSI/ASME B30.21 and HST-3 standards.

Record your purchase information here for quick reference:

Model No.:	Stock No.:	Serial No.:
Purchased From:		Date Purchased:

Specifications (JLH-75/100/150/250WO)

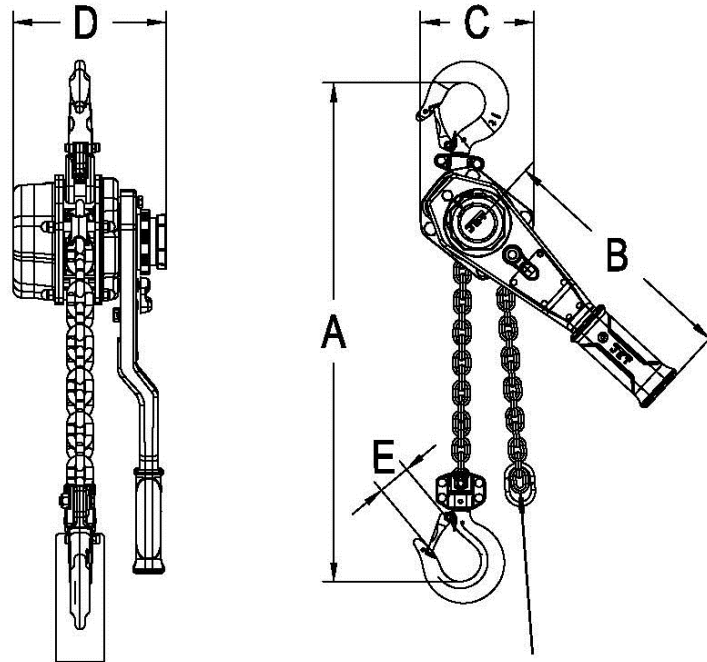

Stock Number	Description	Rated Capcty. (ton)	Standard Lift (ft.)	Min. Distance between hooks (in.) "A"	No. of falls	Load Chain Diameter (mm)	Lift per full turn (in.)	Lbs. Pull to Lift capacity	Lever Length (in.) "B"	(in.) "C"	Overall width (in.) "D"	Hook Throat Opening (in.) "E"	Net Weight (lbs)
376100	JLH-75WO-5	0.75	5	11.02	1	5.6	1.14	63.88	10.24	4.69	5.67	0.93	13.07
376101	JLH-75WO-10	0.75	10	11.02	1	5.6	1.14	63.88	10.24	4.69	5.67	0.93	15.38
376102	JLH-75WO-15	0.75	15	11.02	1	5.6	1.14	63.88	10.24	4.69	5.67	0.93	17.69
376103	JLH-75WO-20	0.75	20	11.02	1	5.6	1.14	63.88	10.24	4.69	5.67	0.93	20
376200	JLH-100WO-5	1	5	11.81	1	5.6	1.14	79.30	10.24	4.69	5.67	1.14	13.6
376201	JLH-100WO-10	1	10	11.81	1	5.6	1.14	79.30	10.24	4.69	5.67	1.14	15.91
376202	JLH-100WO-15	1	15	11.81	1	5.6	1.14	79.30	10.24	4.69	5.67	1.14	18.22
376203	JLH-100WO-20	1	20	11.81	1	5.6	1.14	79.30	10.24	4.69	5.67	1.14	20.53
376300	JLH-150WO-5	1.5	5	13.19	1	7.1	0.86	74.89	10.24	4.96	6.38	1.26	17.94
376301	JLH-150WO-10	1.5	10	13.19	1	7.1	0.86	74.89	10.24	4.96	6.38	1.26	21.75
376302	JLH-150WO-15	1.5	15	13.19	1	7.1	0.86	74.89	10.24	4.96	6.38	1.26	25.56
376303	JLH-150WO-20	1.5	20	13.19	1	7.1	0.86	74.89	10.24	4.96	6.38	1.26	29.37
376400	JLH-250WO-5	2.5	5	14.76	1	8.8	0.60	81.50	10.24	5.90	6.97	1.44	25
376401	JLH-250WO-10	2.5	10	14.76	1	8.8	0.60	81.50	10.24	5.90	6.97	1.44	30.55
376402	JLH-250WO-15	2.5	15	14.76	1	8.8	0.60	81.50	10.24	5.90	6.97	1.44	36.1
376403	JLH-250WO-20	2.5	20	14.76	1	8.8	0.60	81.50	10.24	5.90	6.97	1.44	41.65

NOTE: The above stock numbers are representative; chain is available in other lengths. Specify length when ordering. Some models are available with point ("shipyard") hooks; specify when ordering.

Specifications (JLH-300/600/900)

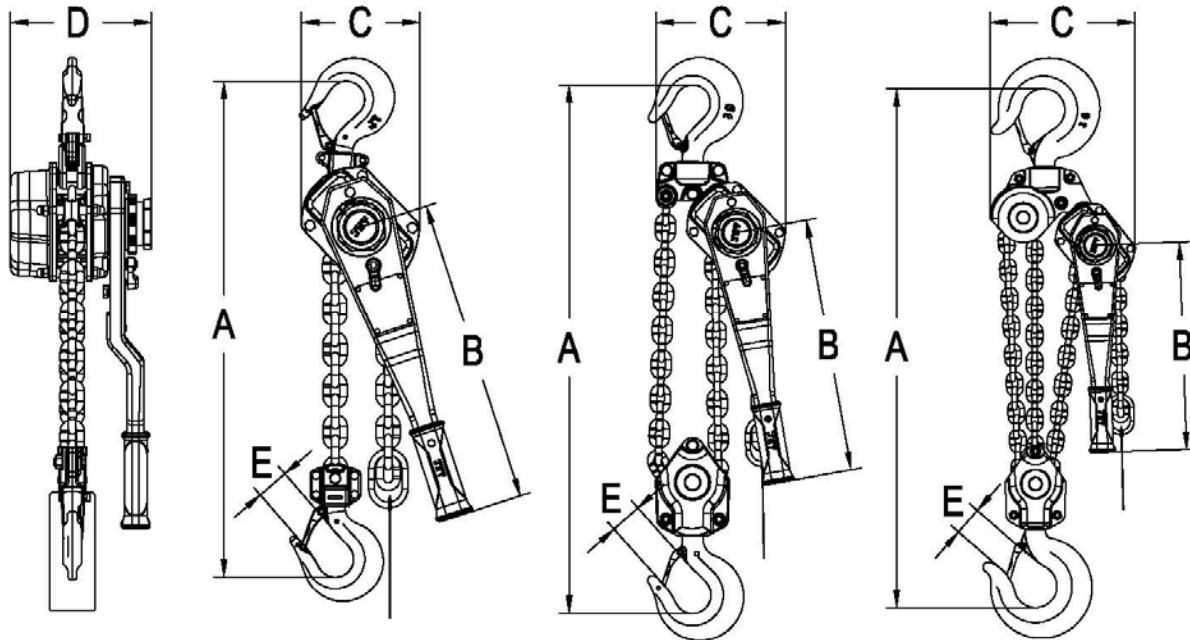

Stock Number	Description	Rated Capcty. (ton)	Standard Lift (ft.)	Min. Distance between hooks (in.) "A"	No. of falls	Load Chain Diameter (mm)	Lift per full turn (in.)	Lbs. Pull to Lift capacity	Lever Length (in.) "B"	(in.) "C"	Overall width (in.) "D"	Hook Throat Opening (in.) "E"	Net Weight (lbs)
376500	JLH-300WO-5	3	5	15.55	1	10	0.762	81.50	16.34	6.26	7.52	1.54	33.07
376501	JLH-300WO-10	3	10	15.55	1	10	0.762	81.50	16.34	6.26	7.52	1.54	40.57
376502	JLH-300WO-15	3	15	15.55	1	10	0.762	81.50	16.34	6.26	7.52	1.54	48.07
376503	JLH-300WO-20	3	20	15.55	1	10	0.762	81.50	16.34	6.26	7.52	1.54	55.57
376600	JLH-600WO-5	6	5	21.26	2	10	0.381	83.70	16.34	8.54	7.52	1.97	57.32
376601	JLH-600WO-10	6	10	21.26	2	10	0.381	83.70	16.34	8.54	7.52	1.97	72.32
376602	JLH-600WO-15	6	15	21.26	2	10	0.381	83.70	16.34	8.54	7.52	1.97	87.32
376603	JLH-600WO-20	6	20	21.26	2	10	0.381	83.70	16.34	8.54	7.52	1.97	102.32
376700	JLH-900WO-5	9	5	26.79	3	10	0.254	88.16	16.34	16.3	7.52	2.13	95
376701	JLH-900WO-10	9	10	26.79	3	10	0.254	88.16	16.34	16.3	7.52	2.13	117.5
376702	JLH-900WO-15	9	15	26.79	3	10	0.254	88.16	16.34	16.3	7.52	2.13	140
376703	JLH-900WO-20	9	20	26.79	3	10	0.254	88.16	16.34	16.3	7.52	2.13	162.5

NOTE: The above stock numbers are representative; chain is available in other lengths. Specify length when ordering. Some models are available with point ("shipyard") hooks; specify when ordering.

Unpacking

Open carton and check for shipping damage. Report any damage immediately to your distributor and shipping agent. Do not discard any shipping material until the Lever Hoist is assembled and running properly. Read this entire instruction manual thoroughly for set-up, maintenance and safety instructions.

Contents of the Carton

- 1 Lever Hoist
- 1 Owner's Manual
- 1 Warranty Card

Installation

Support for the hoist may be hook, clevis pin, trolley, or beam clamp. Whatever method of suspension is chosen, the support components **must** be rated equal to, or greater than the capacity of the lever hoist. Supporting structures (such as I-Beams, etc.) should be installed by properly licensed professional installers.

Pre-Operation Inspection

Inspecting the Load Chain

1. A chain stop must be attached to the second-to-last link on the slack end of the chain. See Figure 2.

⚠WARNING Do not operate the hoist with a twisted, kinked or damaged chain. Do not splice the chain.

2. Check that the chain does not twist along its length from hoist to hook. If twist is present on units with multiple falls, the hook must be passed back through the chain loop to remove all twist in the chain.
3. Replace the chain if links are stretched too long or seriously worn on the surface, especially at the points where links contact each other. See "Allowable Limits" on page 12 for measuring chain elongation.
4. Do not use a chain that is seriously rusted or cracked.
5. Periodically apply a light coat of 30-weight oil to the chain. This will create easier operation and prolong the chain's life. For optimum results, clean the chain with an acid-free solution before oiling.

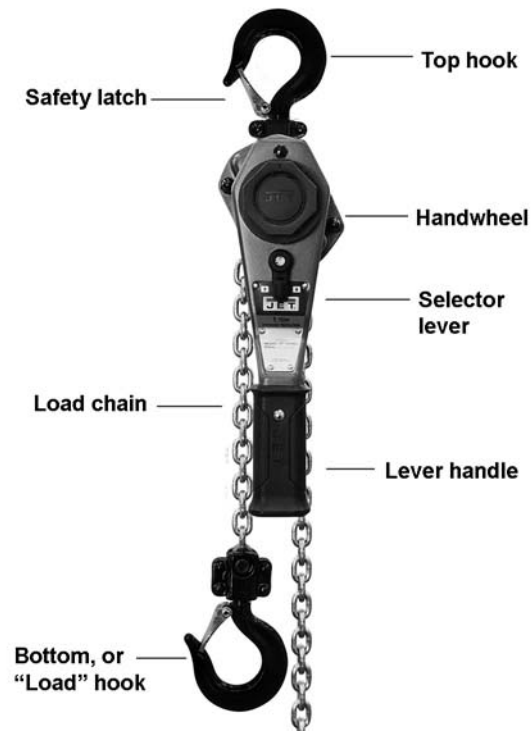

Figure 1
Features and terminology

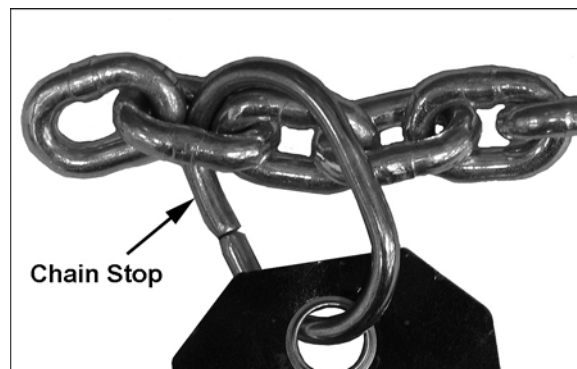

Figure 2

⚠WARNING The load chain supplied with your JET lever hoist is designed, manufactured, and tested for proper fit and durability. If chain should ever need replacing, for your own safety use factory replacement chain only. Use of other than factory replacement chain may cause serious injury and/or damage to the lever hoist.

Never extend load chain by welding a second piece to the original.

Inspecting Hooks

It is important to check top and bottom hooks for proper opening and other signs of deformation or damage. Replace a hook immediately if any of the following problems are identified:

- The safety latch no longer contacts the hook opening.
- The vertical angle at the neck of the hook reaches 10° (see Figure 3).
- Chemical corrosion or cracks on the hook.
- Excessive wear on the inside surface.
- The throat opening has enlarged. (See page 12 for the maximum allowable limits for the throat opening.)

⚠WARNING Do not attempt repair of a hook by heat treating, bending or attaching anything by welding. Such procedures will weaken and may cause failure of the hook.

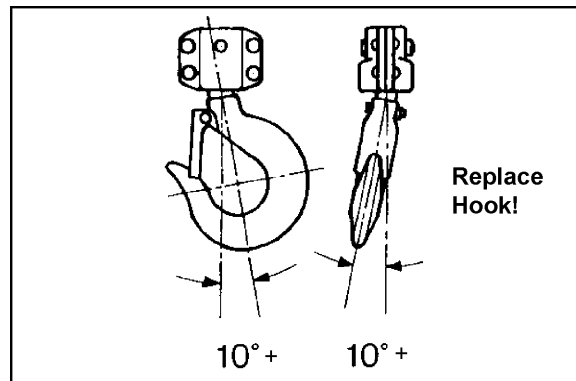

Figure 3

Other Inspections

1. Check for appropriate clicking sounds: With the selector lever in UP position, there will be a clicking sound when the lever handle is rotated in *either direction*. When the selector lever is in DOWN position, there will be a clicking sound only when the lever handle is ratcheted back into position but not as the load is lowered. If these sounds are not present, or if *irregular* clicking noises develop, do not use the hoist – have it inspected and repaired by an authorized service center.
2. If the lever hoist has not been used for an extended period of time, check for proper operation before putting into service.
3. The brake mechanism must be kept clean and free from dirt, water, and oil. Never allow oil to penetrate the braking mechanism. The brake should not slip while using the hoist.

Operation

The JLH Lever Hoist may be used either in vertical position as a hoist; or in angled or horizontal position as a puller. Below is the general procedure for operating the hoist:

1. Set the top hook securely.
2. Place the selector switch on the handle in the center neutral position, and pull out on the handwheel (A, Figure 4). This will allow “free-wheel” mode. Pull the load chain by hand to position the bottom hook.
3. Correctly center the load on the bottom hook (Figure 5). Incorrect loading is dangerous to the operator, the lever hoist, and the load.
 - Never load the hook in front of the safety latch (A, Figure 6).
 - Never load the hook tip (B, Figure 6).
 - Never load the hook off the centerline (C, Figure 6).
 - Never load the hook sideways (D, Figure 6).
4. Rotate the handwheel clockwise while simultaneously pulling down on the load chain, (B, Figure 4). The handwheel will snap back into place, re-engaging the gear.
5. Move selector switch to the UP position. Ratchet the lever to raise or pull the load. Do not overload the lever hoist.

⚠WARNING Do not touch the handwheel while lifting or lowering. Do not operate freewheel mode while there is a load on the hoist.

6. To release or lower the load, turn selector switch on the handle to the DOWN position and ratchet the handle.

NOTE: If the chain is pulled too suddenly in free-wheel mode, the brake may set preventing further pulling. Re-set the hoist by repeating step number 4 above, and then set the hoist back into freewheel mode to continue the operation.

Avoid lifting one load with two hoists. If this is unavoidable, apply equal weight to both hoists and use hoists with the proper lift capacity. **Capacity of each hoist must be equal to the total load to be lifted.**

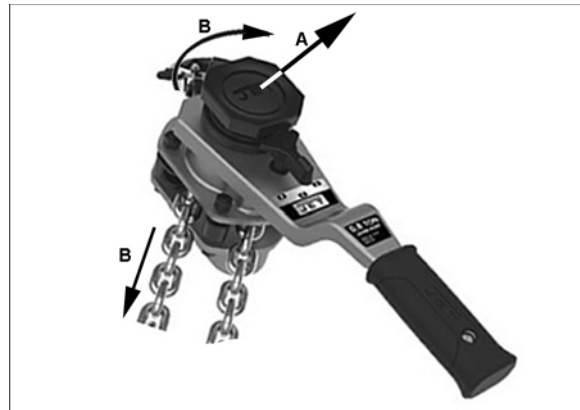

Figure 4

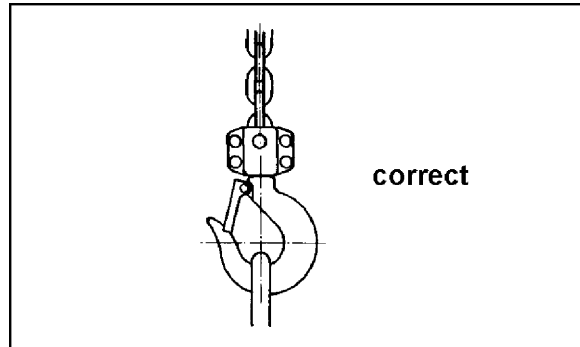

Figure 5

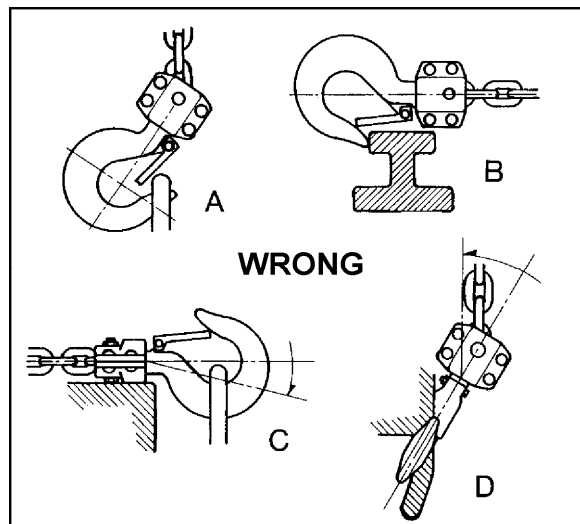

Figure 6

Precautions

- During lifting operations, do not stand under the load.
- Do not use any extension on the lever handle. Do not use your foot to apply pressure to the lever handle.
- Prevent the chain from dragging over sharp edges or corners. This will cause links to weaken, bend, or break.
- When connecting to a wire rope sling, the lever hoist must be applied along a straight line parallel to the surface on which it is resting. See Figure 7.
- When lifting loads, hook the load with slings. **Do not use the lever hoist chain as a sling** (Figure 8).
- Both ends of a sling or rope must be completely on the inside of the safety latch before pulling or lifting the load. Do not put one end on the inside of the latch and leave the other end on the hook end outside the latch.

Point Hooks

Point or “shipyard” hooks are available for your JET lever hoist, in 1.6 ton and 3.2 ton load sizes. They are available in both upper and lower hook styles.

Point hooks are used in the metal and ship building industries, and are designed for positioning steel plate and fixtures before welding.

Overload Protection

All models of the JLH Lever Hoist have overload protection in the form of a slip clutch. The slip clutch is effective at 160% +/-20% of the rated hoist capacity.

The slip clutch will allow the lever handle to rotate without lifting the load, if the load is too heavy for the hoist. The slip clutch has been pre-adjusted at the factory and should not require any adjustment by the user. If future adjustment or repair to the slip clutch should ever be needed, this must be done by qualified personnel.

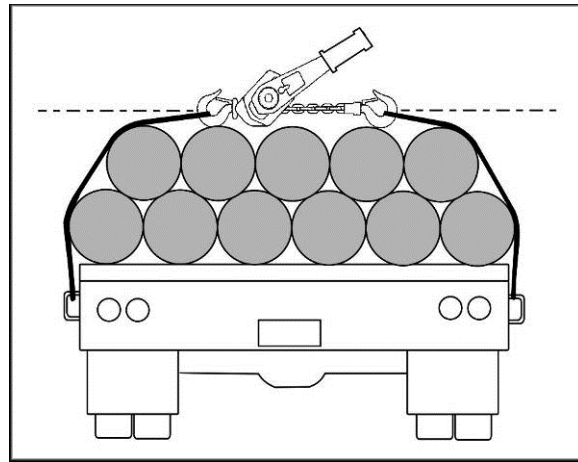

Figure 7

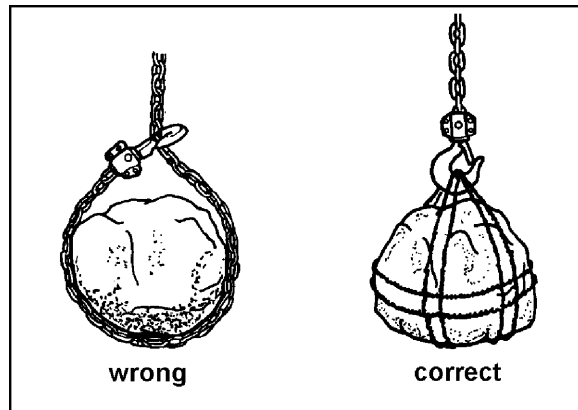

Figure 8

Inspection and Maintenance

Read and follow ANSI Inspection and Maintenance Instructions. Know the meaning of Frequent Inspection, Periodic Inspection, Normal Service, Heavy Service, and Severe Service. It is the customer’s responsibility to understand and follow all ANSI and JET inspection and maintenance instructions.

The lever hoist should be stored in a clean, dry environment. Clean and oil the hoist before storage.

Hoists that are installed out-of-doors should be covered or brought inside when not in use.

Periodically apply a light coat of 30 weight oil to the load chain. Also lubricate

Annually, the hoist should be disassembled, inspected, and cleaned by trained and experienced personnel only. Contact a JET authorized service center by calling your dealer or visiting our web site at jettools.com.

Allowable Limits for Load Chain and Hooks

Load Chain

Carefully inspect the entire load chain. As illustrated in Figure 9, measure five consecutive links with calipers to find the length. Compare the results with the table in Figure 9. Check every three feet and especially where excessive wear is indicated. Any load chain that shows noticeable deformation or heat influence must be replaced with a new one.

⚠WARNING Never extend load chain by welding a second piece to the original.

Hooks (Top and Bottom)

Replace the hook when the distance between indicator points – “A” in Figures 10 and 11 – is wider than the limits given in the table.

Never heat treat the hook or attach anything to the hook by welding.

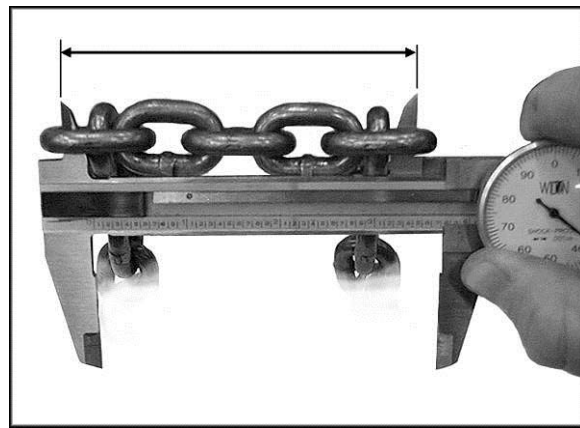

Hoist Capacity	5 Links Normal (mm)	5 Links Limit Replace if ≥
0.8 ton	79	81.3
1 ton	79	81.3
1.6 ton	100	102.9
2.5 ton	124	127.
3.2 ton	141	145.1
6.3 ton	141	145.1
9 ton	141	145.1

Figure 9

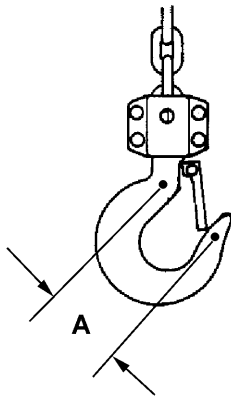

Hoist Capacity	“A” Dimension Normal (mm)	“A” Dimension Replace if ≥
0.8 ton	41.8	44
1 ton	49.9	52.5
1.6 ton	52.3	55
2.5 ton	59.9	63
3.2 ton	62.7	66
6.3 ton	84.6	89

Figure 10

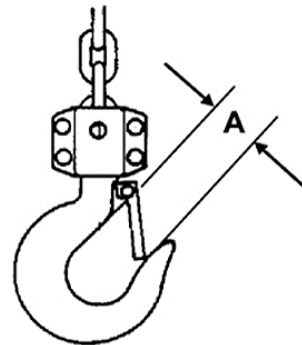

Hoist Capacity	“A” Dimension Normal (mm)	“A” Dimension Replace if ≥
9 ton	54.1	57

Figure 11

Timing Marks for Gear Replacement

If the gears on the JLH hoist need replacement or removal for any reason, make sure they are re-installed correctly. Figure 12 shows the proper orientation of the timing marks when meshing the gears.

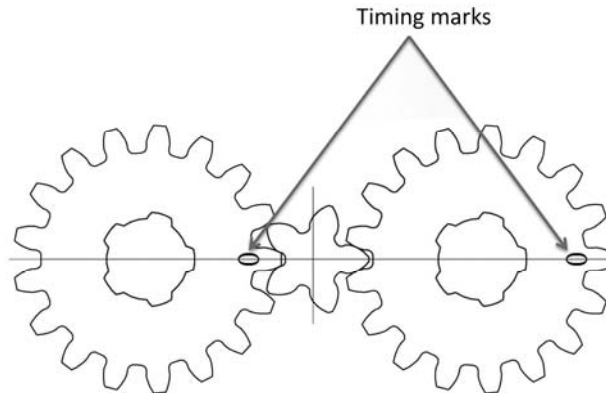

Figure 12

Troubleshooting

The numbers in parentheses refer to the parts breakdown on the following page.

Trouble	Probable Cause	Remedy*
Hoist will not lift (no clicking sound).	Pawl (#12) not engaging ratchet disc (#15); possible dirt or foreign material.	Clean and lubricate pawl/ratchet disc assemblies.
	Pawl spring (#11) is damaged.	Replace pawl spring.
	Selector switch spring (#23) is loose or damaged.	Tighten or replace selector switch spring.
Load slips or drifts while being lowered.	Dirt/corrosion/foreign material in hoist components.	Inspect and correct problem. Keep hoist clean and lubricated.
	Brake is slipping. Disc hub (#14) is worn from long-term use, or is damaged from overloading or misuse.	Replace disc hub. Do not overload hoist.
Hoist will not lower load.	The brake has caught. (Hoist was left under load condition for extended period, or was shock-loaded while operating.)	Place selector lever in DOWN position and pull hard on the lever handle to re-set the brake. Resume operation.
	Brake components are corroded or damaged.	Replace components as needed; keep hoist clean and lubricated.
Handwheel will not move in and out.	Disc hub (#14) is damaged.	Replace disc hub.
Hoist will not freewheel.	Brake has caught because load chain was pulled too hard.	Re-set by rotating handwheel clockwise while pulling down on load chain. Return hoist to freewheel mode and continue. Pull load chain less forcibly.

* Any disassembly or repair of the lever hoist should be performed by properly trained personnel. Call JET, or go to jettools.com to find an authorized Service Center nearest you.

Replacement Parts

Replacement parts are listed on the following pages. To order parts or reach our service department, call 1-800-274-6848 Monday through Friday, 8:00 a.m. to 5:00 p.m. CST. Having the Model Number and Serial Number of your machine available when you call will allow us to serve you quickly and accurately.

JLH Series Lever Hoists (JLH-75/100/150/250/300/600/900WO)

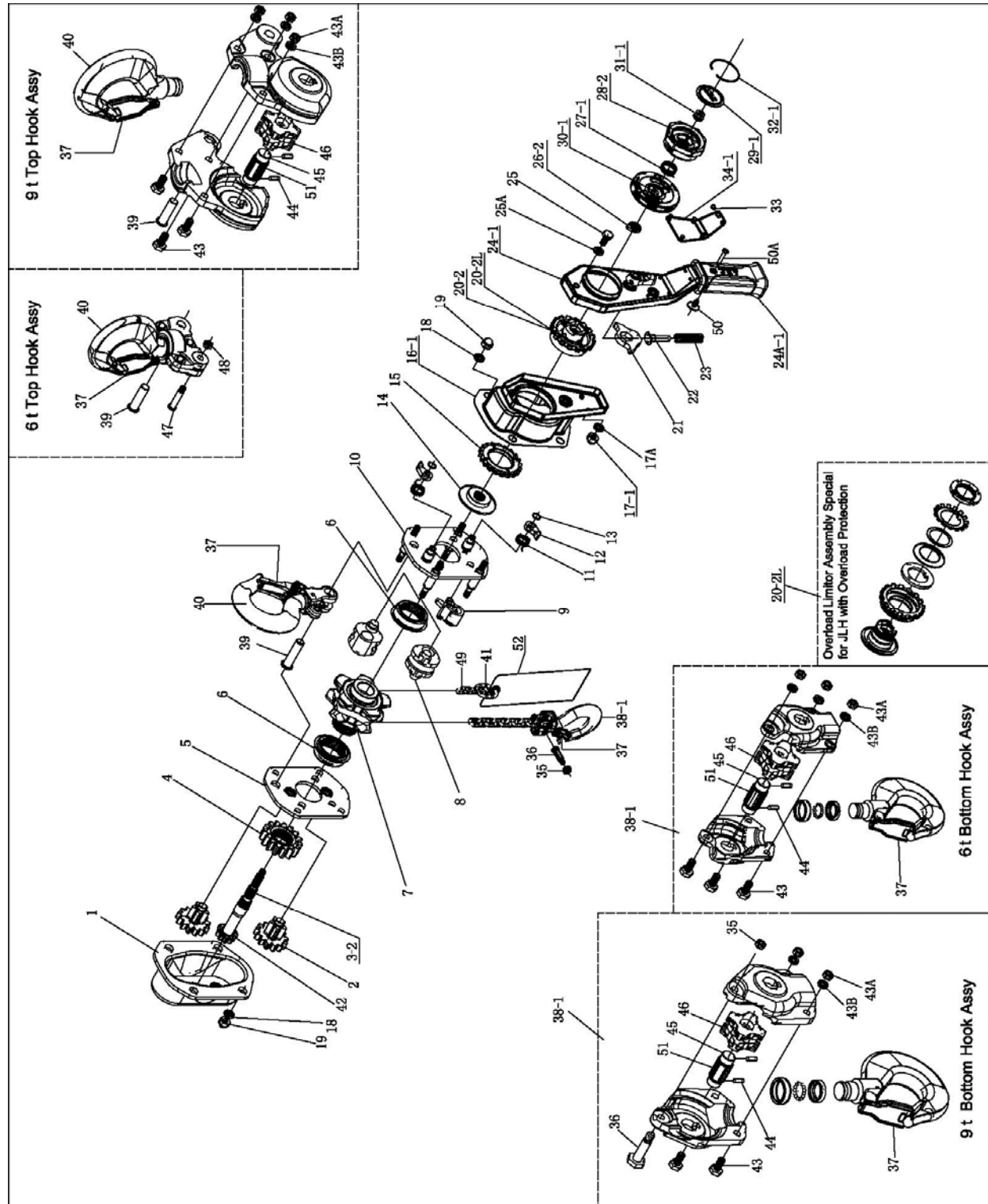

Parts List: JLH-75WO (0.75 Ton)

Non-numbered parts listed under each assembly are parts that make up that assembly.

Index No.	Part No.	Description	Size	Qty
1	JLH80-1G	Gear Case Assembly (0.75, 1 Ton)		1
		Gear Case		1
		Bushing		3
		Cover Plate		1
2	JLH80-2	Spur Gear Assembly (0.75, 1 Ton)		2
		Spur Gear		2
		Pinion Gear		2
3-2	JLH80-3-2	Driving Shaft (0.75, 1 Ton)		1
4	JLH80-4	Load Gear (0.75, 1 Ton)		1
5	JLH80-5	Gear Side Plate Assembly (0.75, 1 Ton)		1
		Gear Side Plate		1
		Bushing		2
6	JLH80-6	Caged Roller Bearings (0.75, 1 Ton)	Ø35xØ25x10mm	2
7	JLH80-7	Load Sheave (0.75, 1 Ton)		1
8	JLH80-8	Guide Roller (0.75, 1 Ton)		2
9	JLH80-9	Stripper (0.75, 1 Ton)		1
10	JLH80-10	Lever Side Plate Assembly (0.75, 1 Ton)		1
		Lever Side Plate		1
		Stay Bolt		4
		Pawl Pin		2
11	JLH80-11	Pawl Spring (0.75, 1 Ton)		2
12	JLH160-12	Pawl (0.75, 1, 1.5 Ton)		2
13	JLH160-13	Snap Ring (0.75, 1, 1.5 Ton)	Ø 9mm	2
14	JLH160-14	Disc Hub (0.75, 1, 1.5, 2.5 Ton)		1
15	JLH160-15	Ratchet Disc (0.75, 1, 1.5, 2.5 Ton)		1
16-1	JLH80-16-1	Brake Cover Assembly (0.75, 1 Ton)		1
		Brake Cover		1
		Handle Case		1
		Bushing		1
		Thread Housing		1
17-1	JLH160-17G	Acorn Nut (0.75, 1, 1.5, 2.5 Ton)	M6	2
17A	JLH160-17AG	Lock Washer (0.75, 1, 1.5, 2.5 Ton)	6mm	2
18	JLH80-18G	Lock Washer (0.75 to 9 Ton)	8mm	8
19	JLH80-19G	Acorn Nut (0.75 to 9 Ton)	M8	8
20-2	JLH160-20-2	Change Over Gear (0.75, 1, 1.5, 2.5 Ton)		1
20-2L	JLH80-20L-2	Overload Limiter Assembly		1
		Overload Limiting Plate		1
		Change Over Gear		1
		Pressure Plate		1
		Dish Spring		1
		Washer		1
		Lock Washer		1
		Round Nut	M30x1	1
21	JLH160-21	Change Over Pawl (0.75, 1, 1.5, 2.5 Ton)		1
22	JLH160-22	Spring Shaft (0.75, 1, 1.5, 2.5 Ton)		1
23	JLH160-23	Spring (0.75, 1, 1.5, 2.5 Ton)		1
24-1	JLH80-24-1	Lever Handle Assembly (0.75, 1, 1.5, 2.5 Ton)		1
		Lever Handle		1
		Selector Lever		1
		Change Over Shaft		1
		Bolt		2
		Spring Seat		1
		Bushing		1
24A-1	JLH80-24A-1	Rubber Grip (0.75, 1, 1.5, 2.5 Ton)		1
25	JLH160-25G	Hex Cap Screw (0.75, 1, 1.5 Ton)	M6 x 12	1
25A	JLH160-25AG	Lock Washer (0.75, 1, 1.5 Ton)	6mm	1
26-2	JLH160-26-2A	Stop Knob (0.75, 1, 1.5, 2.5 Ton)		1
27-1	JLH160-27-1	Twisting Spring (0.75, 1, 1.5, 2.5 Ton)		1

Index No.	Part No.	Description	Size	Qty
28-2	JLH160-28-2	Hand Wheel Assembly (0.75, 1, 1.5, 2.5 Ton)		1
		Hand Wheel		1
		Steel Ball Spring		2
		Steel Ball		2
29-1	JLH160-29-1	Hand Wheel Cap (0.75, 1, 1.5, 2.5 Ton)		1
30-1	JLH160-30-1	Hand Wheel Base Assembly (0.75, 1, 1.5, 2.5 Ton)		
		Hand Wheel Base		1
		Bushing		2
31-1	F001754	Lock Nut	M8	1
32-1	JLH80-32-1	Steel Cable Ring (0.75 to 2.5 Ton)		1
33	JLH80-33	Rivet (0.75 to 9 Ton)	3 x 6mm	6
34-1	LM000191	Name Plate JLH-75		1
35	F001753	Lock Nut	M6	1
36	JLH80-36	Bottom Hook Shaft (0.75, 1 Ton)		1
37	JLH80-37-1	Safety Latch Kit (0.75 Ton)		2
		Safety Latch		2
		Double Spring		2
		Socket Cap Screw	M4 x 23	2
		Lock Nut	M4	2
38	JLH80-38-1	Bottom Hook Assembly (incls. 35 & 36)		1
		Bottom Hook		1
		Safety Latch		1
		Double Spring		1
		Socket Cap Screw	M4 x 23	1
		Lock Nut	M4	1
		Bottom Hook Holder		2
		Rivet	6 x 24mm	4
39	JLH80-39	Top Hook Shaft (0.75, 1 Ton)		1
40	JLH80-40-1	Top Hook Assembly		1
		Top Hook		1
		Safety Latch		1
		Double Spring		1
		Socket Cap Screw	M4 x 23	1
		Lock Nut	M4	1
		Top Hook Holder		2
		Rivet	6 x 24mm	2
41	JLH80-41	Chain Stop (0.75, 1 Ton)		1
42	JLH80-42	Drive Shaft Washer (0.75, 1 Ton)		1
49	JLH80-49	Load Chain (0.75, 1 Ton) – <i>specify length</i>	#100,Ø5.6 x 15.7mm	1
50	JLH160-50	Rubber Grip Fastening (0.75, 1, 1.5, 2.5 Ton)		1
50A	JLH160-50A	Fastening Screw (0.75, 1, 1.5, 2.5 Ton)		1
	JLH-5027WL	Warning Label (not shown)	50x27mm	1
52	L100-WT	Pendant Warning Tag		1

Note: Top and bottom hooks are sold as an assembly only.
When ordering replacement chain (#49), specify length.

Parts List: JLH-100WO (1 Ton)

Non-numbered parts listed under each assembly are parts that make up that assembly.

Index No.	Part No.	Description	Size	Qty
1	JLH80-1G	Gear Case Assembly (0.75, 1 Ton)		1
		Gear Case		1
		Bushing		3
		Cover Plate		1
2	JLH80-2	Spur Gear Assembly (0.75, 1 Ton)		2
		Spur Gear		2
		Pinion Gear		2
3-2	JLH80-3-2	Driving Shaft (0.75, 1 Ton)		1
4	JLH80-4	Load Gear (0.75, 1 Ton)		1
5	JLH80-5	Gear Side Plate Assembly (0.75, 1 Ton)		1
		Gear Side Plate		1
		Bushing		2
6	JLH80-6	Caged Roller Bearings (0.75, 1 Ton)	Ø35xØ25x10mm	2
7	JLH80-7	Load Sheave (0.75, 1 Ton)		1
8	JLH80-8	Guide Roller (0.75, 1 Ton)		2
9	JLH80-9	Stripper (0.75, 1 Ton)		1
10	JLH80-10	Lever Side Plate Assembly (0.75, 1 Ton)		1
		Lever Side Plate		1
		Stay Bolt		4
		Pawl Pin		2
11	JLH80-11	Pawl Spring (0.75, 1 Ton)		2
12	JLH160-12	Pawl (0.75, 1, 1.5 Ton)		2
13	JLH160-13	Snap Ring (0.75, 1, 1.5, 2.5 Ton)	Ø 9mm	2
14	JLH160-14	Disc Hub (0.75, 1, 1.5, 2.5 Ton)		1
15	JLH160-15	Ratchet Disc (0.75, 1, 1.5, 2.5 Ton)		1
16-1	JLH80-16-1	Brake Cover Assembly (0.75, 1 Ton)		1
		Brake Cover		1
		Handle Case		1
		Bushing		1
		Thread Housing		1
17-1	JLH160-17G	Acorn Nut (0.75, 1, 1.5, 2.5 Ton)	M6	2
17A	JLH160-17AG	Lock Washer (0.75, 1, 1.5, 2.5 Ton)	6mm	2
18	JLH80-18G	Lock Washer (0.75 to 9 Ton)	8mm	8
19	JLH80-19G	Acorn Nut (0.75 to 9 Ton)	M8	8
20-2	JLH160-20-2	Change Over Gear (0.75, 1, 1.5, 2.5 Ton)		1
20-2L	JLH100-20L-2	Overload Limiter Assembly		1
		Overload Limiting Plate		1
		Change Over Gear		1
		Pressure Plate		1
		Dish Spring		1
		Washer		1
		Lock Washer		1
		Round Nut	M30x1	1
21	JLH160-21	Change Over Pawl (0.75, 1, 1.5, 2.5 Ton)		1
22	JLH160-22	Spring Shaft (0.75, 1, 1.5, 2.5 Ton)		1
23	JLH160-23	Spring (0.75, 1, 1.5, 2.5 Ton)		1
24-1	JLH80-24-1	Lever Handle Assembly (0.75, 1, 1.5, 2.5 Ton)		1
		Lever Handle		1
		Selector Lever		1
		Change Over Shaft		1
		Bolt		2
		Spring Seat		1
		Bushing		1
24A-1	JLH80-24A-1	Rubber Grip (0.75, 1, 1.5, 2.5 Ton)		1
25	JLH160-25G	Hex Cap Screw (0.75, 1, 1.5 Ton)	M6 x 12	1
25A	JLH160-25AG	Lock Washer (0.75, 1, 1.5 Ton)	6mm	1
26-2	JLH160-26-2A	Stop Knob (0.75, 1, 1.5, 2.5 Ton)		1
27-1	JLH160-27-1	Twisting Spring (0.75, 1, 1.5, 2.5 Ton)		1

Index No.	Part No.	Description	Size	Qty
28-2	JLH160-28-2	Hand Wheel Assembly (0.75, 1, 1.5, 2.5 Ton)		1
		Hand Wheel		1
		Steel Ball Spring		2
		Steel Ball		2
29-1	JLH160-29-1	Hand Wheel Cap (0.75, 1, 1.5, 2.5 Ton)		1
30-1	JLH160-30-1	Hand Wheel Base Assembly (0.75, 1, 1.5, 2.5 Ton)		1
		Hand Wheel Base		1
		Bushing		2
31-1	F001754	Lock Nut	M8	1
32-1	JLH80-32-1	Steel Cable Ring (0.75 to 2.5 Ton)		1
33	JLH80-33	Rivet (0.75 to 9 Ton)	3 x 6mm	6
34-1	LM000191	Name Plate JLH-100		1
35	F001753	Lock Nut	M6	1
36	JLH80-36	Bottom Hook Shaft (0.75, 1 Ton)		1
37	JLH100-37-1	Safety Latch Kit (1 Ton)		2
		Safety Latch		2
		Double Spring		2
		Socket Cap Screw	M4 x 23	2
		Lock Nut	M4	2
38	JLH100-38-1	Bottom Hook Assembly (incls. 35 & 36)		1
		Bottom Hook		1
		Safety Latch		1
		Double Spring		1
		Socket Cap Screw	M4 x 23	1
		Lock Nut	M4	1
		Bottom Hook Holder		2
		Rivet	6 x 24mm	4
39	JLH80-39	Top Hook Shaft (0.75, 1 Ton)		1
40	JLH100-40-1	Top Hook Assembly (1 Ton)		1
		Top Hook		1
		Safety Latch		1
		Double Spring		1
		Socket Cap Screw	M4 x 23	1
		Lock Nut	M4	1
		Top Hook Holder		2
		Rivet	6 x 24mm	2
41	JLH80-41	Chain Stop (0.75, 1 Ton)		1
42	JLH80-42	Drive Shaft Washer (0.75, 1 Ton)		1
49	JLH80-49	Load Chain (0.75, 1 Ton) – <i>specify length</i>	#100,Ø5.6 x 15.7mm	1
50	JLH160-50	Rubber Grip Fastening (0.75, 1, 1.5, 2.5 Ton)		1
50A	JLH160-50A	Fastening Screw (0.75, 1, 1.5, 2.5 Ton)		1
	JLH-5027WL	Warning Label (not shown)	50x27mm	1
52	L100-WT	Warning Tag		1

Note: Top and bottom hooks are sold as an assembly only.
When ordering replacement chain (#49), specify length.

Parts List: JLH-150WO (1.5 Ton)

Non-numbered parts listed under each assembly are parts that make up that assembly.

Index No.	Part No.	Description	Size	Qty
1	JLH160-1G	Gear Case Assembly		1
		Gear Case		1
		Bushing		3
		Cover Plate		1
2	JLH160-2	Spur Gear Assembly		2
		Spur Gear		2
		Pinion Gear		2
3-2	JLH160-3-2	Driving Shaft		1
4	JLH160-4	Load Gear		1
5	JLH160-5	Gear Side Plate Assembly		1
		Gear Side Plate		1
		Bushing		2
6	JLH160-6	Caged Roller Bearings	Ø30xØ40x13mm	2
7	JLH160-7	Load Sheave		1
8	JLH160-8	Guide Roller		2
9	JLH160-9	Stripper		1
10	JLH160-10	Lever Side Plate Assembly		1
		Lever Side Plate		1
		Stay Bolt		4
		Pawl Pin		2
11	JLH160-11	Pawl Spring		2
12	JLH160-12	Pawl (0.75, 1, 1.5 Ton)		2
13	JLH160-13	Snap Ring (0.75, 1, 1.5, 2.5 Ton)	Ø 9mm	2
14	JLH160-14	Disc Hub (0.75, 1, 1.5, 2.5 Ton)		1
15	JLH160-15	Ratchet Disc (0.75, 1, 1.5, 2.5 Ton)		1
16-1	JLH160-16-1	Brake Cover Assembly		1
		Brake Cover		1
		Handle Case		1
		Bushing		1
		Thread Housing		1
17-1	JLH160-17G	Acorn Nut (0.75, 1, 1.5, 2.5 Ton)	M6	2
17A	JLH160-17AG	Lock Washer (0.75, 1, 1.5, 2.5 Ton)	6mm	2
18	JLH80-18G	Lock Washer (0.75 to 9 Ton)	8mm	8
19	JLH80-19G	Acorn Nut (0.75 to 9 Ton)	M8	8
20-2	JLH160-20-2	Change Over Gear (0.75, 1, 1.5, 2.5 Ton)		1
20-2L	JLH160-20L-2	Overload Limiter Assembly		1
		Overload Limiting Plate		1
		Change Over Gear		1
		Pressure Plate		1
		Dish Spring		1
		Washer		1
		Lock Washer		1
		Round Nut	M30x1	1
21	JLH160-21	Change Over Pawl (0.75, 1, 1.5, 2.5 Ton)		1
22	JLH160-22	Spring Shaft (0.75, 1, 1.5, 2.5 Ton)		1
23	JLH160-23	Spring (0.75, 1, 1.5, 2.5 Ton)		1
24-1	JLH80-24-1	Lever Handle Assembly(0.75, 1, 1.5, 2.5 Ton)		1
		Lever Handle		1
		Selector Lever		1
		Change Over Shaft		1
		Bolt		2
		Spring Seat		1
		Bushing		1
24A-1	JLH80-24A-1	Rubber Grip (0.75, 1, 1.5, 2.5 Ton)		1
25	JLH160-25G	Hex Cap Screw (0.75, 1, 1.5 Ton)	M6 x 12	1
25A	JLH160-25AG	Lock Washer (0.75, 1, 1.5 Ton)	6mm	1
26-2	JLH160-26-2A	Stop Knob (0.75, 1, 1.5, 2.5 Ton)		1
27-1	JLH160-27-1	Twisting Spring I (0.75, 1, 1.5, 2.5 Ton)		1

Index No.	Part No.	Description	Size	Qty
28-2	JLH160-28-2	Hand Wheel Assembly (0.75, 1, 1.5, 2.5 Ton)		1
		Hand Wheel		1
		Steel Ball Spring		2
		Steel Ball		2
29-1	JLH160-29-1	Hand Wheel Cap (0.75, 1, 1.5, 2.5 Ton)		1
30-1	JLH160-30-1	Hand Wheel Base Assembly (0.75, 1, 1.5, 2.5 Ton)		1
		Hand Wheel Base		1
		Bushing		2
31-1	F001754	Lock Nut	M8	1
32-1	JLH80-32-1	Steel Cable Ring (0.75 to 2.5Ton)		1
33	JLH80-33	Rivet (0.75 to 9 Ton)	3 x 6mm	6
34-1	LM000193	Name Plate JLH-160		1
35	F001755	Lock Nut	M8	1
36	JLH160-36	Bottom Hook Shaft		1
37	JLH160-37-1	Safety Latch Kit		2
		Safety Latch		2
		Double Spring		2
		Socket Cap Screw	M4 x 23	2
		Lock Nut	M4	2
38	JLH160-38-1	Bottom Hook Assembly (incls. 35 & 36)		1
	JLH160-38PH-1	Bottom Point Hook Assembly (incls. 35 & 36)		1
		Bottom Hook		1
		Safety Latch		1
		Double Spring		1
		Socket Cap Screw	M4 x 23	1
		Lock Nut	M4	1
		Bottom Hook Holder		2
		Rivet	6 x 24mm	4
39	JLH160-39	Top Hook Shaft		1
40	JLH160-40-1	Top Hook Assembly		1
	JLH160-40PH-1	Top Point Hook Assembly		1
		Top Hook		1
		Safety Latch		1
		Double Spring		1
		Socket Cap Screw	M4 x 23	1
		Lock Nut	M4	1
		Top Hook Holder		2
		Rivet	6 x 24mm	2
41	JLH160-41	Chain Stop		1
42	JLH160-42	Drive Shaft Washer		1
49	JLH160-49	Load Chain – <i>specify length</i>	#100,Ø7.1 x 19.9mm	1
50	JLH160-50	Rubber Grip Fastening (0.75, 1, 1.5, 2.5 Ton)		1
50A	JLH160-50A	Fastening Screw (0.75, 1, 1.5, 2.5 Ton)		1
	JLH-5027WL	Warning Label (not shown)	50x27mm	1
52	L100-WT	Warning Tag		1

Note: Top and bottom hooks are sold as an assembly only. Both standard and point hooks are available for the 1.5 ton model, as listed above.

When ordering replacement chain (#49), specify length.

Parts List: JLH-250WO (2.5 Ton)

Non-numbered parts listed under each assembly are parts that make up that assembly.

Index No.	Part No.	Description	Size	Qty
1	JLH250-1G	Gear Case Assembly		1
		Gear Case		1
		Bushing		3
		Cover Plate		1
2	JLH250-2	Spur Gear Assembly		2
		Spur Gear		2
		Pinion Gear		2
3-2	JLH250-3-2	Driving Shaft		1
4	JLH250-4	Load Gear		1
5	JLH250-5	Gear Side Plate Assembly		1
		Gear Side Plate		1
		Bushing		2
6	JLH250-6	Caged Roller Bearings	Ø35xØ45x14mm	2
7	JLH250-7	Load Sheave		1
8	JLH250-8	Guide Roller		2
9	JLH250-9	Stripper		1
10	JLH250-10	Lever Side Plate Assembly		1
		Lever Side Plate		1
		Stay Bolt		4
		Pawl Pin		2
11	JLH250-11	Pawl Spring		2
12	JLH250-12	Pawl		2
13	JLH160-13	Snap Ring (0.75, 1, 1.5, 2.5 Ton)	Ø 9mm	2
14	JLH160-14	Disc Hub (0.75, 1, 1.5, 2.5 Ton)		1
15	JLH160-15	Ratchet Disc (0.75, 1, 1.5, 2.5 Ton)		1
16-1	JLH250-16-1	Brake Cover Assembly		1
		Brake Cover		1
		Handle Case		1
		Bushing		1
		Thread Housing		1
17-1	JLH160-17G	Acorn Nut (0.75, 1, 1.5, 2.5 Ton)	M6	2
17A	JLH160-17AG	Lock Washer (0.75, 1, 1.5, 2.5 Ton)	6mm	2
18	JLH80-18G	Lock Washer (0.75 to 9 Ton)	8mm	8
19	JLH80-19G	Acorn Nut (0.75 to 9 Ton)	M8	8
20-2	JLH160-20-2	Change Over Gear (0.75, 1, 1.5, 2.5 Ton)		1
20-2L	JLH250-20L-2	Overload Limiter Assembly		1
		Overload Limiting Plate		1
		Change Over Gear		1
		Pressure Plate		1
		Dish Spring		1
		Washer		1
		Lock Washer		1
		Round Nut	M30x1	1
21	JLH160-21	Change Over Pawl (0.75, 1, 1.5, 2.5 Ton)		1
22	JLH160-22	Spring Shaft (0.75, 1, 1.5, 2.5 Ton)		1
23	JLH160-23	Spring (0.75, 1, 1.5, 2.5 Ton)		1
24-1	JLH80-24-1	Lever Handle Assembly		1
		Lever Handle		1
		Selector Lever		1
		Change Over Shaft		1
		Bolt		2
		Spring Seat		1
		Bushing		1
24A-1	JLH80-24A-1	Rubber Grip (0.75, 1, 1.5, 2.5 Ton)s		1
25	F008745	Hex Cap Screw (2.5, 3, 6 Ton)	M6x12	1
25A	F002111	Lock Washer (2.5, 3, 6 Ton)	6mm	1
26-2	JLH160-26-2A	Stop Knob (0.75, 1, 1.5, 2.5 Ton)		1
27-1	JLH160-27-1	Twisting Spring (0.75, 1, 1.5, 2.5 Ton)		1

Index No.	Part No.	Description	Size	Qty
28-2	JLH160-28-2	Hand Wheel Assembly (0.75, 1, 1.5, 2.5 Ton)		1
		Hand Wheel		1
		Steel Ball Spring		2
		Steel Ball		2
29-1	JLH160-29-1	Hand Wheel Cap (0.75, 1, 1.5, 2.5 Ton)		1
30-1	JLH160-30-1	Hand Wheel Base Assembly (0.75, 1, 1.5, 2.5 Ton)		1
		Hand Wheel Base		1
		Bushing		2
31-1	F001754	Lock Nut	M8	1
32-1	JLH80-32-1	Steel Cable Ring (0.75 to 2.5 Ton)		1
33	JLH80-33	Rivet (0.75 to 2.5 Ton)	3 x 6mm	6
34-1	LM000194	Name Plate JLH-250		1
35	F001755	Lock Nut	M10	1
36	JLH250-36	Bottom Hook Shaft		1
37	JLH250-37-1	Safety Latch Kit		2
		Safety Latch		2
		Double Spring		2
		Socket Cap Screw	M6 x 33	2
		Lock Nut	M6	2
38	JLH250-38-1	Bottom Hook Assembly (incls. 35 & 36)		1
		Bottom Hook		1
		Safety Latch		1
		Double Spring		1
		Socket Cap Screw	M6 x 33	1
		Lock Nut	M6	1
		Bottom Hook Holder		2
		Rivet	7 x 25mm	4
39	JLH250-39	Top Hook Shaft		1
40	JLH250-40-1	Top Hook Assembly		1
		Top Hook		1
		Safety Latch		1
		Double Spring		1
		Socket Cap Screw	M6 x 33	1
		Lock Nut	M6	1
		Top Hook Holder		2
		Rivet	7 x 25mm	2
41	JLH250-41	Chain Stop		1
42	JLH250-42	Drive Shaft Washer		1
49	JLH250-49	Load Chain – <i>specify length</i>	#100,Ø8.8 x 24.6mm	1
50	JLH160-50	Rubber Grip Fastening (0.75, 1, 1.5, 2.5 Ton)		1
50A	JLH160-50A	Fastening Screw (0.75, 1, 1.5, 2.5 Ton)		1
	JLH-7040WL	Warning Label (not shown)	70x40mm	1
52	L100-WT	Warning Tag		1

Note: Top and bottom hooks are sold as an assembly only.
When ordering replacement chain (#49), specify length.

Parts List: JLH-300WO (3 Ton)

Non-numbered parts listed under each assembly are parts that make up that assembly.

Index No.	Part No.	Description	Size	Qty
1	JLH320-1G	Gear Case Assembly (3, 6, 9 Ton)		1
		Gear Case		1
		Bushing		3
		Cover Plate		1
2	JLH320-2	Spur Gear Assembly (3, 6, 9 Ton)		2
		Spur Gear		2
		Pinion Gear		2
3-2	JLH320-3-2	Driving Shaft (3, 6, 9 Ton)		1
4	JLH320-4	Load Gear (3, 6, 9 Ton)		1
5	JLH320-5	Gear Side Plate Assembly (3, 6, 9 Ton)		1
		Gear Side Plate		1
		Bushing		2
6	JLH320-6	Caged Roller Bearings (3, 6, 9 Ton)	Ø40xØ50x15mm	2
7	JLH320-7	Load Sheave (3, 6, 9 Ton)		1
8	JLH320-8	Guide Roller (3, 6, 9 Ton)		2
9	JLH320-9	Stripper (3, 6, 9 Ton)		1
10	JLH320-10	Lever Side Plate Assembly (3, 6, 9 Ton)		1
		Lever Side Plate		1
		Stay Bolt		4
		Pawl Pin		2
11	JLH320-11	Pawl Spring (3, 6, 9 Ton)		2
12	JLH320-12	Pawl (3, 6, 9 Ton)		2
13	JLH320-13	Snap Ring (3, 6, 9 Ton)	Ø 10mm	2
14	JLH320-14	Disc Hub (3, 6, 9 Ton)		1
15	JLH320-15	Ratchet Disc (3, 6, 9 Ton)		1
16-1	JLH320-16-1	Brake Cover Assembly (3, 6, 9 Ton)		1
		Brake Cover		1
		Handle Case		1
		Bushing		1
		Thread Housing		1
17-1	JLH320-17G	Acorn Nut (3, 6, 9 Ton)	M8	2
17A	JLH320-17AG	Lock Washer (3, 6, 9 Ton)	8mm	2
18	JLH80-18G	Lock Washer (0.75 to 9 Ton)	8mm	8
19	JLH80-19G	Acorn Nut (0.75 to 9 Ton)	M8	8
20-2	JLH320-20-2	Change Over Gear (3, 6, 9 Ton)		1
20-2L	JLH320-20L-2	Overload Limiter Assembly		1
		Overload Limiting Plate		1
		Change Over Gear		1
		Pressure Plate		1
		Dish Spring		1
		Washer		1
		Lock Washer		1
		Round Nut	M30x1	1
21	JLH320-21	Change Over Pawl (3, 6, 9 Ton)		1
22	JLH320-22	Spring Shaft (3, 6, 9 Ton)		1
23	JLH320-23	Spring (3, 6, 9 Ton)		1
24-1	JLH320-24-1	Lever Handle Assembly (3, 6, 9 Ton)		1
		Lever Handle		1
		Selector Lever		1
		Change Over Shaft		1
		Bolt		2
		Spring Seat		1
		Bushing		1
24A-1	JLH320-24A-1	Rubber Grip (3, 6, 9 Ton)		1
25	F008785	Hex Cap Screw (2.5, 3, 6, 9 Ton)	M8 x 16	1
25A	JLH320-25AG	Lock Washer (2.5, 3, 6, 9 Ton)	8mm	1
26-2	JLH320-26-2A	Stop Knob (3, 6, 9 Ton)		1
27-1	JLH320-27-1	Twisting Spring (3, 6, 9 Ton)		1

Index No.	Part No.	Description	Size	Qty
28-2	JLH320-28-2	Hand Wheel Assembly (3, 6, 9 Ton)		1
		Hand Wheel		1
		Steel Ball Spring		2
		Steel Ball		2
29-1	JLH320-29-1	Hand Wheel Cap (3, 6, 9 Ton)		1
30-1	JLH320-30-1	Hand Wheel Base Assembly (3, 6, 9 Ton)		1
		Hand Wheel Base		1
		Bushing		2
31-1	F001755	Lock Nut	M10	1
32-1	JLH320-32-1	Steel Cable Ring (3 to 9 Ton)		1
33	JLH80-33	Rivet (0.75 to 9 Ton)	3 x 6mm	4
34-1	LM000195	Name Plate JLH-300		1
35	F001755	Lock Nut	M10	1
36	JLH320-36	Bottom Hook Shaft		1
37	JLH320-37-1	Safety Latch Kit		2
		Safety Latch		2
		Double Spring		2
		Socket Cap Screw	M6 x 33	2
		Lock Nut	M6	2
38	JLH320-38-1	Bottom Hook Assembly (incls. 35 & 36)		1
	JLH320-38PH-1	Bottom Point Hook Assembly (incls. 35 & 36)		1
		Bottom Hook		1
		Safety Latch		1
		Double Spring		1
		Socket Cap Screw	M6 x 33	1
		Lock Nut	M6	1
		Bottom Hook Holder		2
		Rivet	7 x 25mm	4
39	JLH320-39	Top Hook Shaft (3, 6, 9 Ton)		1
40	JLH320-40	Top Hook Assembly		1
	JLH320-40PH-1	Top Point Hook Assembly		1
		Top Hook		1
		Safety Latch		1
		Double Spring		1
		Socket Cap Screw	M6 x 33	1
		Lock Nut	M6	1
		Top Hook Holder		2
		Rivet	7 x 25mm	2
41	JLH320-41	Chain Stop (3, 6, 9 Ton)		1
42	JLH320-42	Drive Shaft Washer (3, 6, 9 Ton)		1
49	JLH320-49	Load Chain (3, 6, 9 Ton) – <i>specify length</i>	#100, Ø10 x 18mm	1
50	JLH320-50	Rubber Grip Fastening (3, 6, 9 Ton)		1
50A	JLH320-50A	Fastening Screw (3, 6, 9 Ton)		1
	JLH-7040WL	Warning Label (not shown)	70x40mm	1
52	L100-WT	Warning Tag		1

Note: Top and bottom hooks are sold as an assembly only. Both standard and point hooks are available for the 3 ton model, as listed above.

When ordering replacement chain (#49), specify length.

Parts List: JLH-600WO (6 Ton)

Non-numbered parts listed under each assembly are parts that make up that assembly.

Index No.	Part No.	Description	Size	Qty
1	JLH320-1G	Gear Case Assembly (3, 6, 9 Ton)		1
		Gear Case		1
		Bushing		3
		Cover Plate		1
2	JLH320-2	Spur Gear Assembly (3, 6, 9 Ton)		2
		Spur Gear		2
		Pinion Gear		2
3-2	JLH320-3-2	Driving Shaft (3, 6, 9 Ton)		1
4	JLH320-4	Load Gear (3, 6, 9 Ton)		1
5	JLH320-5	Gear Side Plate Assembly (3, 6, 9 Ton)		1
		Gear Side Plate		1
		Bushing		2
6	JLH320-6	Caged Roller Bearings (3, 6, 9 Ton)	Ø40xØ50x15mm	2
7	JLH320-7	Load Sheave (3, 6, 9 Ton)		1
8	JLH320-8	Guide Roller (3, 6, 9 Ton)		2
9	JLH320-9	Stripper (3, 6, 9 Ton)		1
10	JLH320-10	Lever Side Plate Assembly (3, 6, 9 Ton)		1
		Lever Side Plate		1
		Stay Bolt		4
		Pawl Pin		2
11	JLH320-11	Pawl Spring (3, 6, 9 Ton)		2
12	JLH320-12	Pawl (3, 6, 9 Ton)		2
13	JLH320-13	Snap Ring (3, 6, 9 Ton)	Ø 10mm	2
14	JLH320-14	Disc Hub (3, 6, 9 Ton)		1
15	JLH320-15	Ratchet Disc (3, 6, 9 Ton)		1
16-1	JLH320-16-1	Brake Cover Assembly (3, 6, 9 Ton)		1
		Brake Cover		1
		Handle Case		1
		Bushing		1
		Thread Housing		1
17-1	JLH320-17G	Acorn Nut (3, 6, 9 Ton)	M8	2
17A	JLH320-17AG	Lock Washer (3, 6, 9 Ton)	8mm	2
18	JLH80-18G	Lock Washer (0.75 to 9 Ton)	8mm	8
19	JLH80-19G	Acorn Nut (0.75 to 9 Ton)	M8	8
20-2	JLH320-20-2	Change Over Gear (3, 6, 9 Ton)		1
20-2L	JLH630-20L-2	Overload Limiter Assembly		1
		Overload Limiting Plate		1
		Change Over Gear		1
		Pressure Plate		1
		Dish Spring		1
		Washer		1
		Lock Washer		1
		Round Nut	M30x1	1
21	JLH320-21	Change Over Pawl (3, 6, 9 Ton)		1
22	JLH320-22	Spring Shaft (3, 6, 9 Ton)		1
23	JLH320-23	Spring (3, 6, 9 Ton)		1
24-1	JLH320-24-1	Lever Handle Assembly (3, 6, 9 Ton)		1
		Lever Handle		1
		Selector Lever		1
		Change Over Shaft		1
		Bolt		2
		Spring Seat		1
		Bushing		1
24A-1	JLH320-24A-1	Rubber Grip (3, 6, 9 Ton)		1
25	F008785	Hex Cap Screw (2.5, 3, 6, 9 Ton)	M8 x 16	1
25A	JLH320-25AG	Lock Washer (2.5, 3, 6, 9 Ton)	8mm	1
26-2	JLH320-26-2A	Stop Knob (3, 6, 9 Ton)		1
27-1	JLH320-27-1	Twisting Spring (3, 6, 9 Ton)		1

Index No.	Part No.	Description	Size	Qty
28-2	JLH320-28-2	Hand Wheel Assembly (3, 6, 9 Ton)		1
		Hand Wheel		1
		Steel Ball Spring		2
		Steel Ball		2
29-1	JLH320-29-1	Hand Wheel Cap (3, 6, 9 Ton)		1
30-1	JLH320-30-1	Hand Wheel Base Assembly (3, 6, 9 Ton)		1
		Hand Wheel Base		1
		Bushing		2
31-1	F001755	Lock Nut	M10	1
32-1	JLH80-32-1	Steel Cable Ring (3 to 9 Ton)		1
33	JLH80-33	Rivet (0.75 to 9 Ton)	3 x 6mm	4
34-1	LM000196	Name Plate JLH-600		1
37	JLH630-37-1	Safety Latch Kit		2
		Safety Latch		2
		Double Spring		2
		Socket Cap Screw	M6 x 33	2
		Lock Nut	M6	2
38	JLH630-38-1	Bottom Hook Assembly (incls. 35 & 36)		1
		Bottom Hook		1
		Safety Latch		1
		Double Spring		1
		Socket Cap Screw	M6 x 33	1
		Lock Nut	M6	1
		Bottom Hook Holder		2
		Socket Cap Screw	M10 x 32	3
		Lock Nut	M10	3
		Straight Pin	Ø8 x 18mm	2
		Idle Shaft		1
		Idle Sheave		1
		Needle Bearing		29
39	JLH320-39	Top Hook Shaft (3, 6, 9 Ton)		1
40	JLH630-40-1	Top Hook Assembly		1
		Top Hook		1
		Safety Latch		1
		Double Spring		1
		Socket Cap Screw	M6 x 33	1
		Lock Nut	M6	1
		Top Hook Holder		2
		Rivet	10 x 34mm	3
41	JLH320-41	Chain Stop (3, 6, 9 Ton)		1
42	JLH320-42	Drive Shaft Washer (3, 6, 9 Ton)		1
43	JLH630-43	Socket Cap Screw (includes 43A nut, 43B washer)	M10 x 30	3
44	JLH630-44	Straight Pin	Ø8 x 18	2
45	JLH630-45	Idle Shaft (6, 9T)		1
46	JLH630-46	Idle Sheave (6, 9T)		1
47	JLH630-47	Chain Pin		1
48	F001755	Lock Nut	M10	1
49	JLH320-49	Load Chain (3, 6, 9 Ton) – specify length	#100,Ø10 x 28mm	2
50	JLH320-50	Rubber Grip Fastening (3, 6, 9 Ton)		1
50A	JLH320-50A	Fastening Screw (3, 6, 9 Ton)		1
51	JLH900-51	Needle Bearing		29
	JLH-7040WL	Warning Label (not shown)	70x40mm	1
52	L100-WT	Warning Tag		1

Note: Top and bottom hooks are sold as an assembly only.
When ordering replacement chain (#49), specify length.

Parts List: JLH-900 (9 Ton)

Non-numbered parts listed under each assembly are parts that make up that assembly.

Index No.	Part No.	Description	Size	Qty
1	JLH320-1G	Gear Case Assembly (3, 6, 9 Ton)		1
		Gear Case		1
		Bushing		3
		Cover Plate		1
2	JLH320-2	Spur Gear Assembly (3, 6, 9 Ton)		2
		Spur Gear		2
		Pinion Gear		2
3-2	JLH320-3-2	Driving Shaft (3, 6, 9 Ton)		1
4	JLH320-4	Load Gear (3, 6 Ton)		1
5	JLH320-5	Gear Side Plate Assembly (3, 6, 9 Ton)		1
		Gear Side Plate		1
		Bushing		2
6	JLH320-6	Caged Roller Bearings (3, 6, 9 Ton)	Ø40xØ50x15mm	2
7	JLH320-7	Load Sheave (3, 6, 9 Ton)		1
8	JLH320-8	Guide Roller (3, 6, 9 Ton)		2
9	JLH320-9	Stripper (3, 6, 9 Ton)		1
10	JLH320-10	Lever Side Plate Assembly (3, 6, 9 Ton)		1
		Lever Side Plate		1
		Stay Bolt		4
		Pawl Pin		2
11	JLH320-11	Pawl Spring (3, 6, 9 Ton)		2
12	JLH320-12	Pawl (3, 6, 9 Ton)		2
13	JLH320-13	Snap Ring (3, 6, 9 Ton)	Ø 10mm	2
14	JLH320-14	Disc Hub (3, 6, 9 Ton)		1
15	JLH320-15	Ratchet Disc (3, 6, 9 Ton)		1
16-1	JLH320-16-1	Brake Cover Assembly (3, 6, 9 Ton)		1
		Brake Cover		1
		Handle Case		1
		Bushing		1
		Thread Housing		1
17-1	JLH320-17G	Acorn Nut (3, 6, 9 Ton)	M8	2
17A	JLH320-17AG	Lock Washer (3, 6, 9 Ton)	8mm	2
18	JLH80-18G	Lock Washer (0.75 to 9 Ton)	8mm	8
19	JLH80-19G	Acorn Nut (0.75 to 9 Ton)	M8	8
20-2	JLH320-20-2	Change Over Gear (3, 6, 9 Ton)		1
20-2L	JLH900-20L-2	Overload Limiter Assembly		1
		Overload Limiting Plate		1
		Change Over Gear		1
		Pressure Plate		1
		Dish Spring		1
		Washer		1
		Lock Washer		1
		Round Nut	M30x1	1
21	JLH320-21	Change Over Pawl (3, 6, 9 Ton)		1
22	JLH320-22	Spring Shaft (3, 6, 9 Ton)		1
23	JLH320-23	Spring (3, 6, 9 Ton)		1
24-1	JLH320-24-1	Lever Handle Assembly (3, 6, 9 Ton)		1
		Lever Handle		1
		Selector Lever		1
		Change Over Shaft		1
		Bolt		2
		Spring Seat		1
		Bushing		1
24A-1	JLH320-24A-1	Rubber Grip (3, 6, 9 Ton)		1
25	F008785	Hex Cap Screw (2.5, 3, 6, 9 Ton)	M8 x 16	1
25A	JLH320-25AG	Lock Washer (2.5, 3, 6, 9 Ton)	8mm	1
26-2	JLH320-26-2A	Stop Knob (3, 6, 9 Ton)		1
27-1	JLH320-27-1	Twisting Spring (3, 6, 9 Ton)		1

Index No.	Part No.	Description	Size	Qty
28-2	JLH320-28-2	Hand Wheel (3, 6, 9 Ton)		1
		Hand Wheel		1
		Steel Ball Spring		2
		Steel Ball		2
29-1	JLH320-29-1	Hand Wheel Cap (3, 6, 9 Ton)		1
30-1	JLH320-30-1	Hand Wheel Base Assembly (3, 6, 9 Ton)		1
		Hand Wheel Base		1
		Bushing		2
31-1	F001755	Lock Nut	M10	1
32-1	JLH80-32-1	Steel Cable Ring (0.75 to 9 Ton)	2 x 18mm	1
33	JLH80-33	Rivet (0.75 to 9 Ton)	3 x 6mm	4
34-1	LM000197	Name Plate JLH-900		1
35	F001755	Lock Nut	M10	1
36	JLH900-35	Chain Pin		1
37	JLH900-37-1	Safety Latch Kit		2
		Safety Latch		2
		Double Spring		2
		Socket Cap Screw	M6 x 33	2
		Lock Nut	M6	2
38	JLH900-38-1	Bottom Hook Assembly (incls. 35 & 36)		1
		Bottom Hook		1
		Safety Latch		1
		Double Spring		1
		Socket Cap Screw	M6 x 33	1
		Lock Nut	M6	1
		Bottom Hook Holder		2
		Socket Cap Screw	M10 x 40	3
		Lock Nut	M10	3
		Straight Pin	Ø8 x 18mm	2
		Idle Shaft		1
		Idle Sheave		1
		Needle Bearing	Ø3 x 40mm	29
39	JLH320-39	Top Hook Shaft (3, 6, 9 Ton)		1
40	JLH900-40-1	Top Hook Assembly		1
		Top Hook		1
		Safety Latch		1
		Double Spring		1
		Socket Cap Screw	M6 x 33	1
		Lock Nut	M6	1
		Top Hook Holder		2
		Socket Cap Screw	M10x40	2
		Lock Nut	M10	2
		Straight Pin	Ø8 x 18mm	2
		Idle Shaft		1
		Idle Sheave		1
		Needle Bearing	Ø3 x 40mm	29
41	JLH320-41	Chain Stop (3, 6, 9 Ton)		1
42	JLH320-42	Drive Shaft Washer (3, 6, 9 Ton)		1
43	JLH630-43	Socket Cap Screw (includes 43A nut, 43B washer)	M10 x 30	5
44	JLH630-44	Straight Pin	Ø8 x 18	2
45	JLH630-45	Idle Shaft (6, 9 Ton)		1
46	JLH630-46	Idle Sheave (6, 9 Ton)		1
49	JLH320-49	Load Chain (3, 6, 9 Ton) – specify length	#100,Ø10 x 28mm	3
50	JLH320-50	Rubber Grip Fastening (3, 6, 9 Ton)		1
50A	JLH320-50A	Fastening Screw (3, 6, 9 Ton)		1
51	JLH900-51	Needle Bearing		2x29
	JLH-7040WL	Warning Label (not shown)	70x40mm	1
52	L100-WT	Warning Tag		1

Note: Top and bottom hooks are sold as an assembly only.
When ordering replacement chain (#49), specify length.